



Submittal Data Sheet

2.0-Ton Multi-Position Air Handler
FTQ24TAVJUDRZQ24TAVJUA

FEATURES

- Designed for zero clearance on three sides and only 24" clearance on the front for service
- Horizontal left, Horizontal right, Upflow & Downflow installation configurations

INDOOR UNIT



OUTDOOR UNIT





Submittal Data Sheet

2.0-Ton Multi-Position Air Handler
FTQ24TAVJUDRZQ24TAVJUA

SYSTEM PERFORMANCE

Indoor Unit Model No.	FTQ24TAVJUD	Indoor Unit Name:	air handler
Outdoor Unit Model No.	RZQ24TAVJUA	Outdoor Unit Name:	Sky-Air 2.0 Ton Heat Pump ODU
Rated Cooling Capacity (Btu/hr):	24,000	Rated Cooling Conditions:	Indoor (°F DB/WB): 80 / 67 Ambient (°F DB/WB): 95 / 75
Sensible Capacity (Btu/hr):	16,900	Rated Piping Length(ft):	25
Max/Min Cooling Capacity (Btu/hr):	/	Rated Height Difference (ft):	0.00
Cooling Input Power (kW):		Rated Heating Conditions:	Indoor (°F DB/WB): 70 / 60 Ambient (°F DB/WB): 47 / 43
SEER (Non-Ducted/Ducted):	/ 15.20		
EER (Non-Ducted/Ducted):	/ 10.30		
Rated Heating Capacity (Btu/hr):	27,000		
Heating Input Power (kW):	0.27		

SYSTEM DETAILS

Refrigerant Type:	R-410A	Cooling Operation Range (°F DB):	23 - 122
Holding Refrigerant Charge (lbs):	6.4	Heating Operation Range (°F WB):	-4 - 60
Additional Charge (lb/ft):	0.04	Max. Pipe Length (Vertical) (ft):	98
Pre-charge Piping (Length) (ft):	15	Cooling Range w/Baffle (°F DB):	0 - 122
Max. Pipe Length (Total) (ft):	164	Heating Range w/Baffle (°F WB):	-
Max Height Separation (Ind to Ind ft):	0		



Submittal Data Sheet

2.0-Ton Multi-Position Air Handler
FTQ24TAVJUDRZQ24TAVJUA

INDOOR UNIT DETAILS

Power Supply (V/Hz/Ph):	208/230 / 60 / 1	Airflow Rate (H) (CFM):	800
Power Supply Connections:	L1, L2, Ground	Moisture Removal (Gal/hr):	
Min. Circuit Amps MCA (A):	4.9	Gas Pipe Connection (inch):	5/8
Max Overcurrent Protection (MOP) (A):	15	Liquid Pipe Connection (inch):	3/8
Dimensions (HxWxD) (in):	45 x 17.5 x 21	Condensate Connection (inch):	3/4
Net Weight (lb):	115	Sound Pressure (H/M/L) (dBA):	45 / 41 / 38
Ext. Static Pressure (Rated/Max) (inWg):	/ 0.9	Sound Power Level (dBA):	

DIMENSIONAL DRAWING - INDOOR UNIT

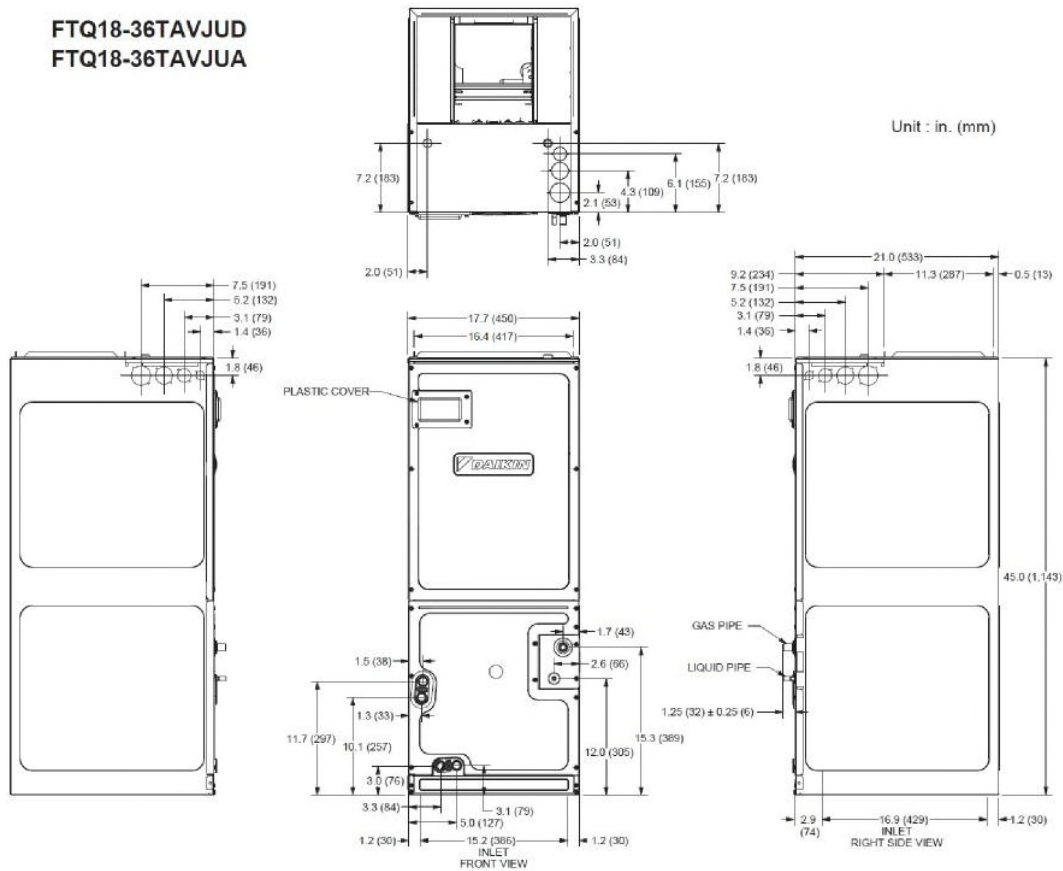

Daikin North America LLC, 5151 San Felipe, Suite 500, Houston, TX, 77056

Daikin City Generated Submittal Data

www.daikinac.com www.daikincomfort.com

(Daikin's products are subject to continuous improvements. Daikin reserves the right to modify product design, specifications and information in this data sheet without notice and without incurring any obligations)

Submittal Date: May 2020

Page 3 of 4



Submittal Data Sheet

2.0-Ton Multi-Position Air Handler
FTQ24TAVJUDRZQ24TAVJUA

OUTDOOR UNIT DETAILS

Power Supply (V/Hz/Ph):	208-230 / 60 / 1	Compressor Stage:	
Power Supply Connections:	L1, L2, Ground	Capacity Control Range (%):	14 - 100
Min. Circuit Amps MCA (A):	16.5	Airflow Rate (H) (CFM):	2862
Max Overcurrent Protection (MOP) (A):	20	Gas Pipe Connection (inch):	5/8
Max Starting Current MSC(A):		Liquid Pipe Connection (inch):	3/8
Rated Load Amps RLA(A):		Sound Pressure (H) (dBA):	58
Dimensions (HxWxD) (in):	39 x 37 x 12-5/8	Sound Power Level (dBA):	
Net Weight (lb):	172		

DIMENSIONAL DRAWING - OUTDOOR UNIT

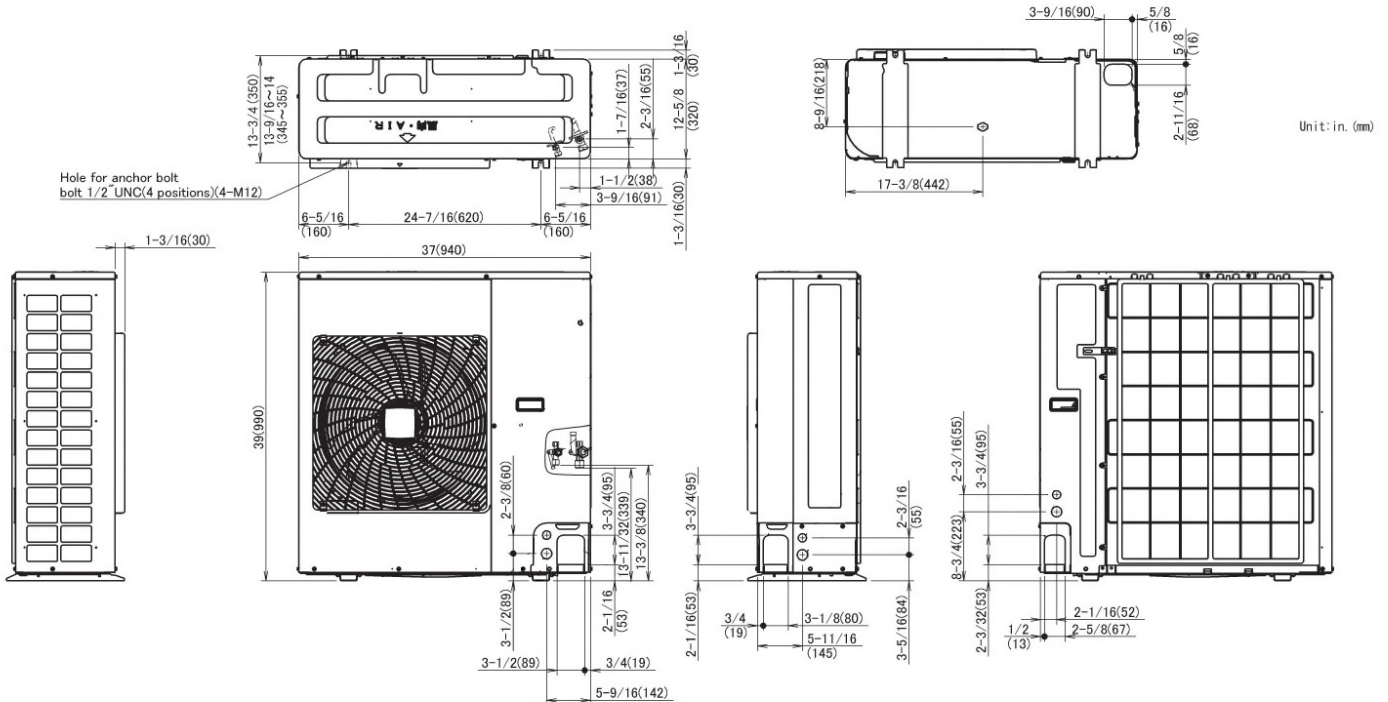

Daikin North America LLC, 5151 San Felipe, Suite 500, Houston, TX, 77056

Daikin City Generated Submittal Data

www.daikinac.com www.daikincomfort.com

(Daikin's products are subject to continuous improvements. Daikin reserves the right to modify product design, specifications and information in this data sheet without notice and without incurring any obligations)

Submittal Date: May 2020

Page 4 of 4